

NOTES:

- 1 VEHICLE CROSSING GRADE MUST BE SET WITH THE USE OF GRADIENT PROFILER BEAM. REFER TO MP307.
- 2 ALL MEASUREMENTS ARE IN MILLIMETRES.
- 3 TO BE READ IN CONJUNCTION TO MP303.

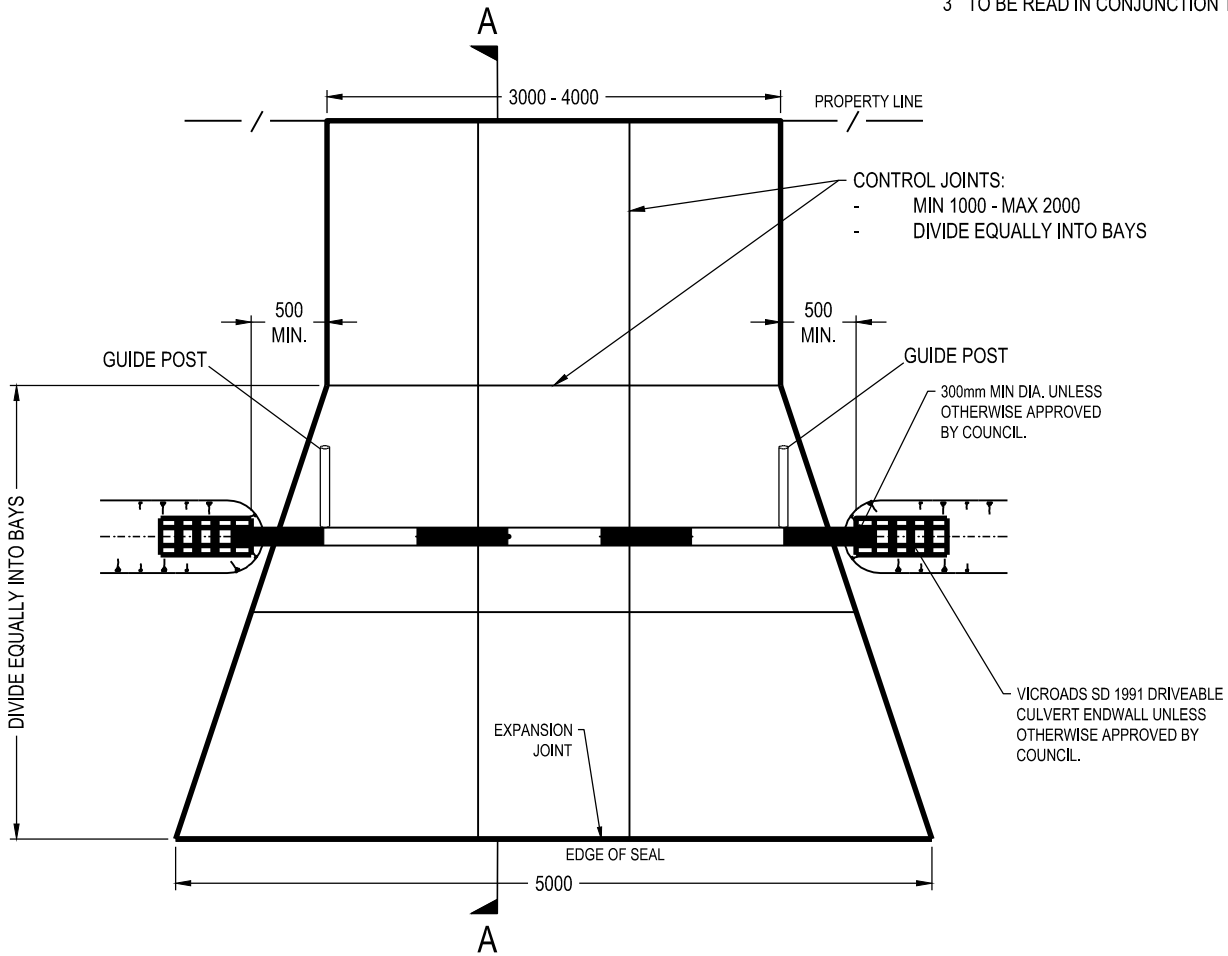

PLAN
SCALE 1:50

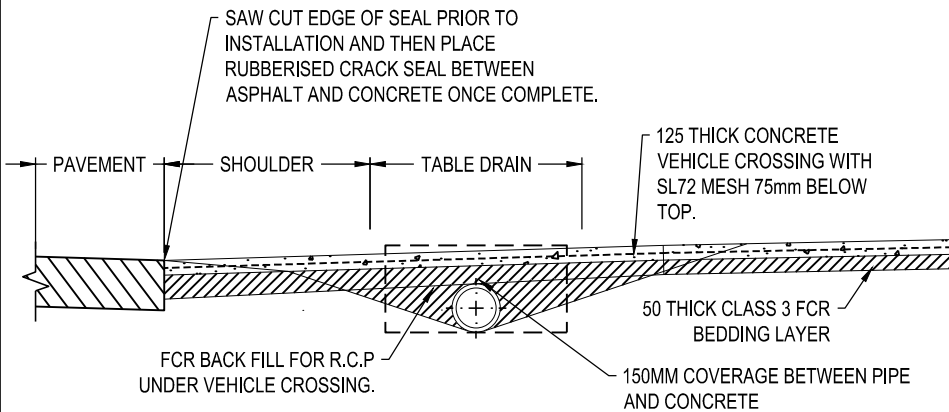

SECTION A-A
NOT TO SCALE



**MORNINGTON
PENINSULA**
Shire

STANDARD PLAN
**TYPICAL RESIDENTIAL VEHICLE
CROSSING - WITH CULVERT**

[Signature]

MANAGER - INFRASTRUCTURE PROJECTS

DATE OF ISSUE
SHEET NO

05/12/2024
1 OF 1

MP313