

PLAN
SCALE 1:20

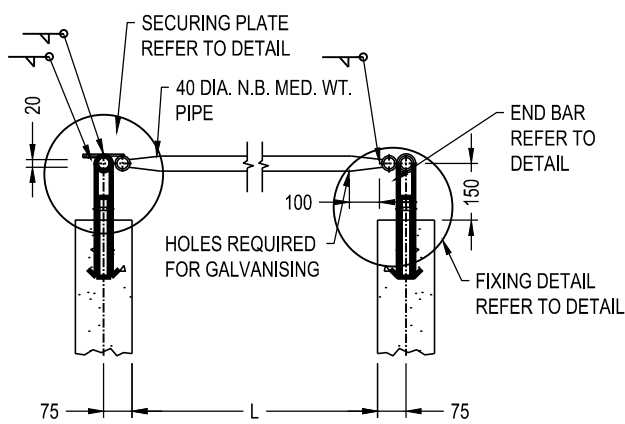

SECTION A-A
SCALE 1:20

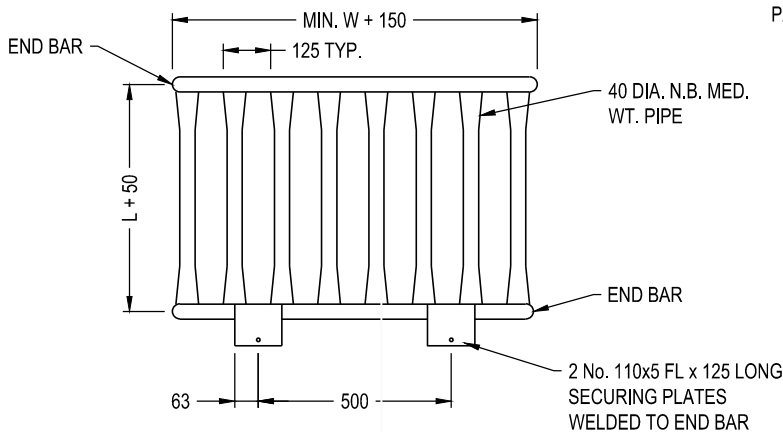

GRILLE PANEL - TYPE 1
SCALE 1:20

NOTE: END BARS TO BE 40 DIA. N.B. HEAVY WT. PIPE

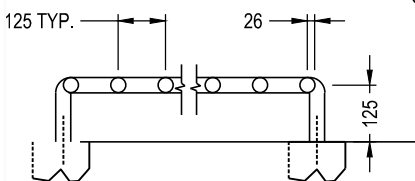

END BAR DETAIL
SCALE 1:20

40 DIA. N.B. HEAVY WT. GRILLE PANEL TYPE 1

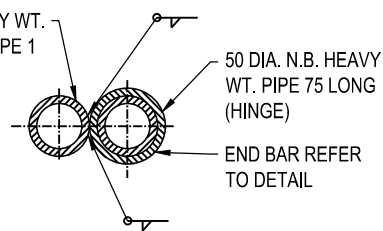

HINGE DETAIL
SCALE 1:5

NOTES:

- 1 ALL WELDS TO BE 6mm FILLET UNLESS SHOWN OTHERWISE.
- 2 AFTER FABRICATION GRILLE AND FIXING RODS TO BE HOT DIPPED GALVANISED IN ACCORDANCE WITH AS/NZ 4680:1999.
- 3 PROVIDE SUITABLE HOLES FOR ALL MATERIALS TO BE GALVANISED AS REQUIRED.
- 4 ALL END BARS TO BE 40 DIA. N.B. HEAVY WT. PIPE.
- 5 ALL MEASUREMENTS ARE IN MILLIMETRES.

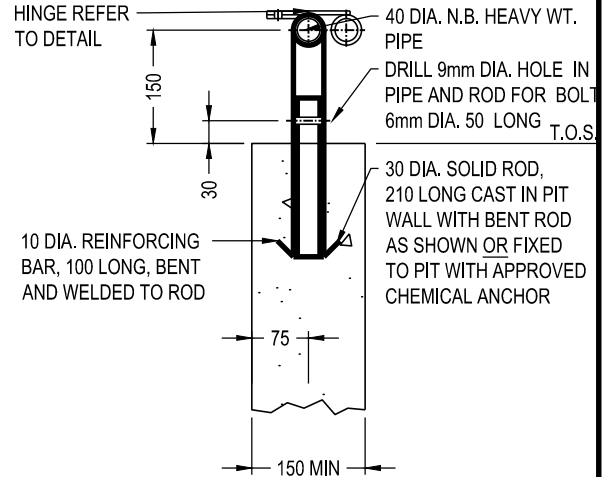

FIXING DETAIL
SCALE 1:20

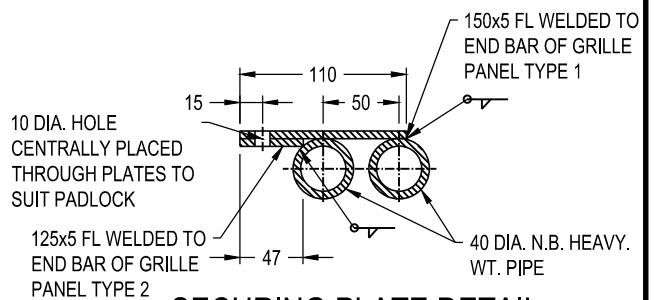

SECURING PLATE DETAIL
SCALE 1:5



MORNINGTON PENINSULA
Shire

STANDARD PLAN
PIPE GRILLE SINGLE HINGED
OPENING FOR PITS UP TO 900 x
1200

[Signature]
MANAGER - INFRASTRUCTURE PROJECTS

DATE OF ISSUE
SHEET NO

05/12/2024
1 OF 1

MP235