

GRATE DETAIL

SCALE 1:10

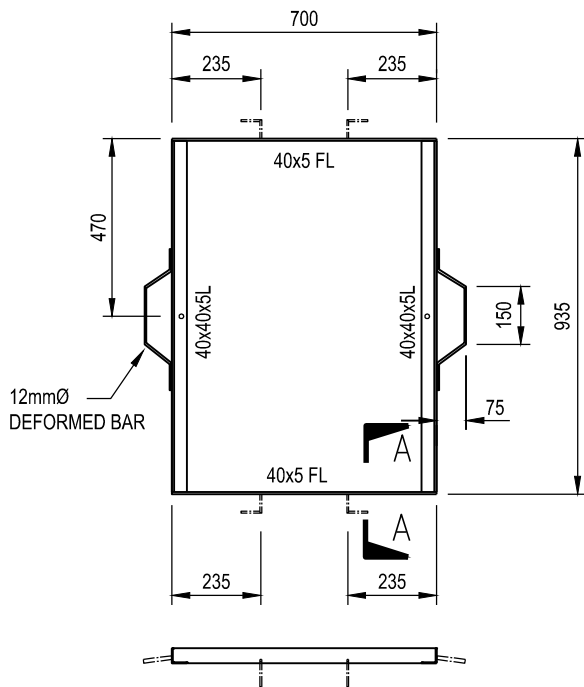

FRAME DETAIL

SCALE 1:20

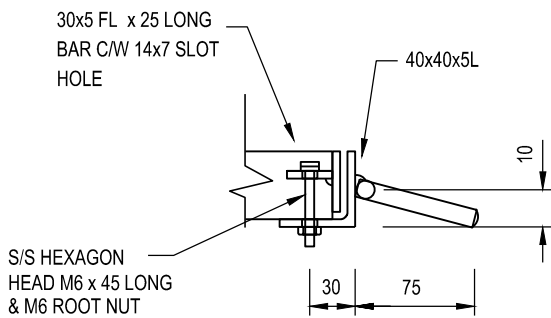

NB: BOLT TO BE SUPPLIED WITH
20mm LONG RUBBER SLEEVE
TO BE CAST INTO CONCRETE

LOCK DOWN DETAIL

SCALE 1:5

NOTES:

- 1 FINISH TO BE HOT DIPPED GALVANISED IN ACCORDANCE WITH AS/NZ 4680:1999.
- 2 WEIGHT:- 40kg.
- 3 ALL MEASUREMENTS ARE IN MILLIMETRES.

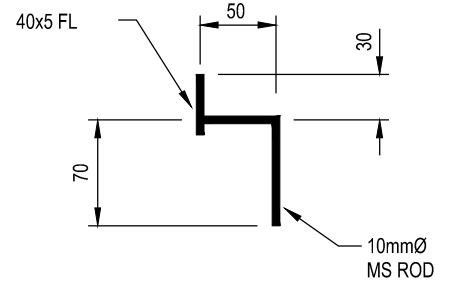

SECTION A-A

SCALE 1:5



**MORNINGTON
PENINSULA**
Shire

STANDARD PLAN
LIGHT DUTY STEEL GRATE &
FRAME FOR STANDARD
SOAKAGE PIT

MANAGER - INFRASTRUCTURE PROJECTS

DATE OF ISSUE
SHEET NO

05/12/2024
1 OF 1

MP222