

NOTES:

- 1 PIT LID TO BE AN APPROVED CLASS B TYPE OR APPROVED EQUIVALENT. FOR FRAME AND LID DETAILS, REFER TO MP232.
- 2 PIT IS TO BE CAST-IN-SITU ONLY.
- 3 STEEL PLATE FINISH TO BE HOT DIPPED GALVANISED IN ACCORDANCE WITH AS/NZ 4680:1999.
- 4 THIS STANDARD NEEDS TO READ CONJUNCTION WITH MP213, MP218, AND MP232.
- 5 ALL MEASUREMENTS ARE IN MILLIMETRES.

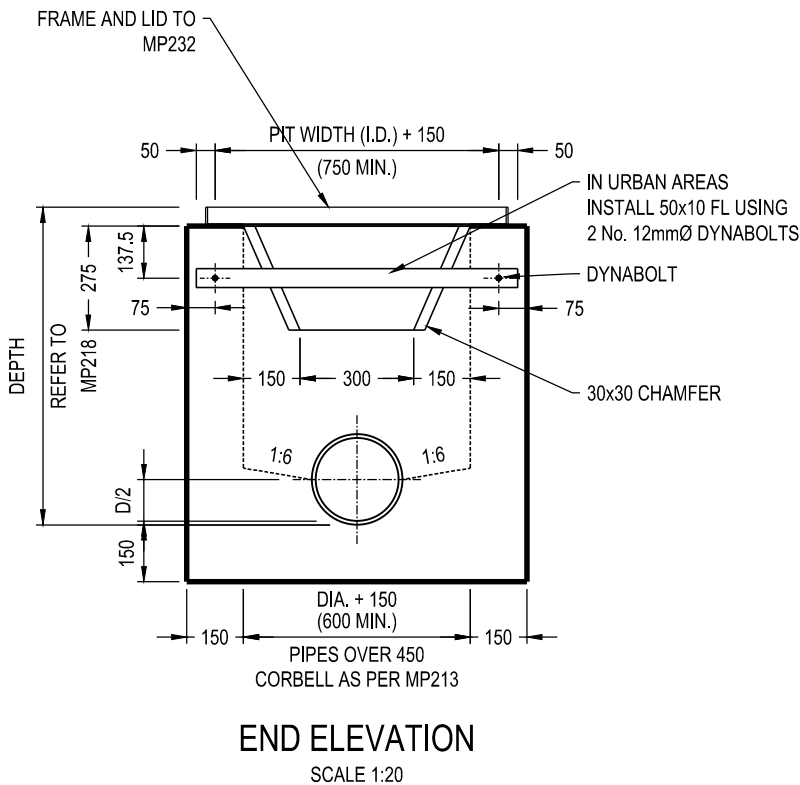
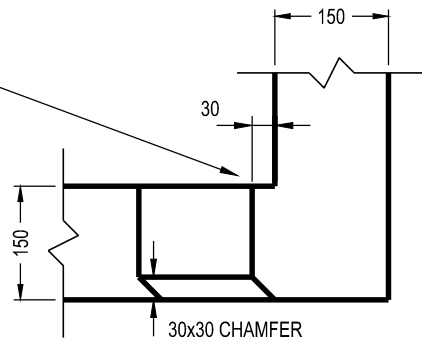
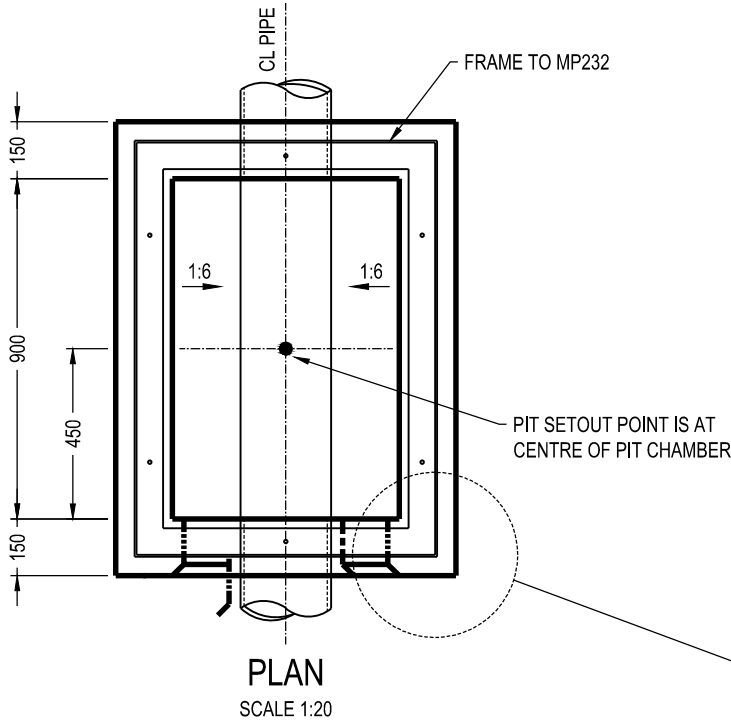

**MORNINGTON
PENINSULA**
Shire

STANDARD PLAN
CATCH PIT 900 x 600 FOR
TABLE DRAINS

MANAGER - INFRASTRUCTURE PROJECTS

DATE OF ISSUE 05/12/2024
SHEET NO 1 OF 1

MP215