

**NOTES:**

- 1 ALL WELDS TO BE 6mm FILLET UNLESS SHOWN OTHERWISE.
- 2 AFTER FABRICATION GRILLE AND FIXING RODS TO BE HOT DIPPED GALVANISED IN ACCORDANCE WITH AS/NZ 4680:1999
- 3 PROVIDE SUITABLE HOLES FOR ALL MATERIALS TO BE GALVANISED AS REQUIRED.
- 4 ALL END BARS TO BE 40 DIA. N.B. HEAVY WT PIPE.
- 5 ALL MEASUREMENTS ARE IN MILLIMETRES.

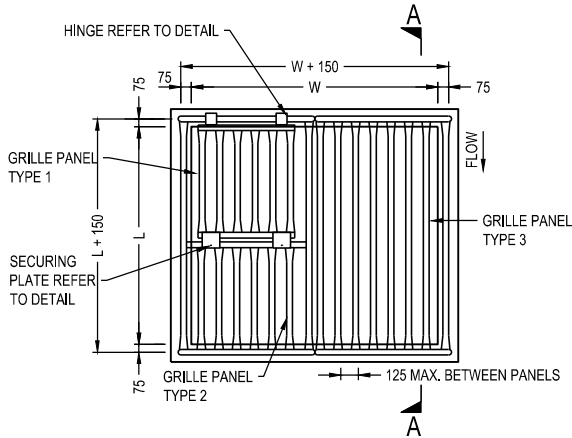

**PLAN**

SCALE 1:40

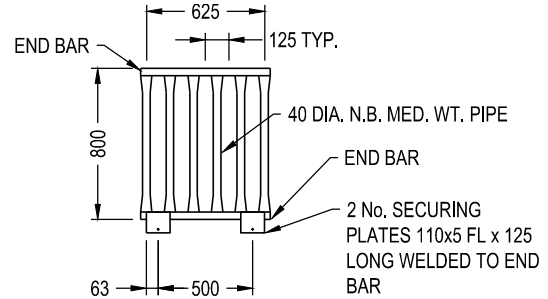

**GRILLE PANEL TYPE 1**

SCALE 1:40

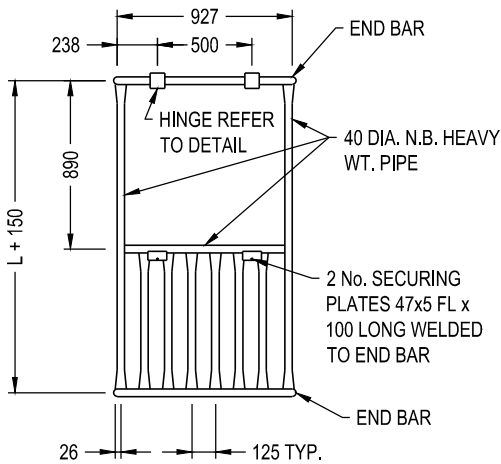

**GRILLE PANEL TYPE 2**

SCALE 1:40

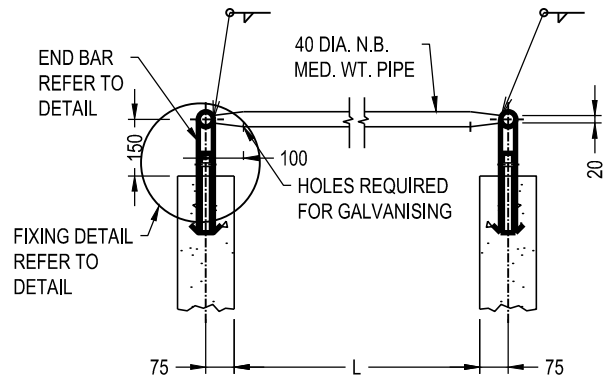

**SECTION A-A**

SCALE 1:20

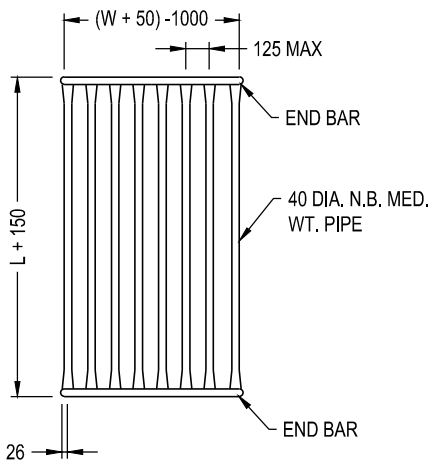

**GRILLE PANEL TYPE 3**

SCALE 1:40



**MORNINGTON  
PENINSULA**  
*Shire*

**STANDARD PLAN**  
PIPE GRILLE FOR PIT OPENING  
GREATER THAN 900 x 900

MANAGER - INFRASTRUCTURE PROJECTS

DATE OF ISSUE  
SHEET NO

05/12/2024  
1 OF 2

**MP229.1**