

NOTES:

1. COUNCIL CONSENT MAY BE GRANTED FOR POST HOLES WHERE THE HOARDING PROPOSED IS FOR A PERIOD EXCEEDING 6 MONTHS OR WHERE THE ENTIRE FOOTPATH IS TO BE REINSTATED BY THE USER.
2. ALL MEASUREMENTS ARE IN MILLIMETRES.

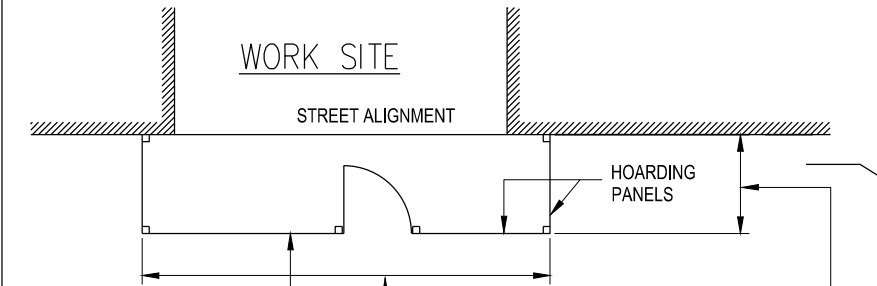

REFER TO COUNCIL FOR LIGHTING REQUIREMENTS

HOARDING SPACE AS APPROVED BY THE CONSTRUCTION AND ASSET PROTECTION DEPARTMENT AND STATED ON HOARDING PERMIT

PLAN

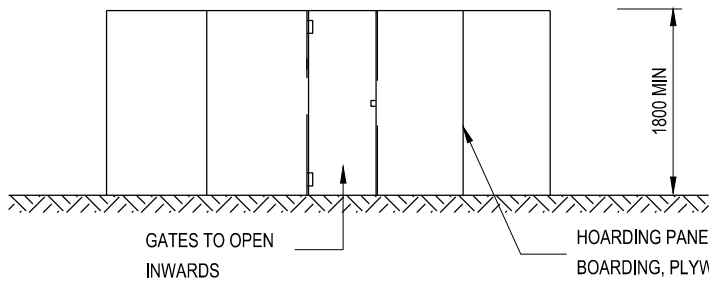

ELEVATION

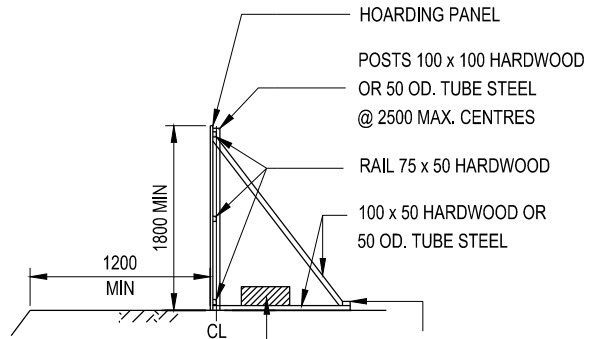

SUPPORTS FOR HOARDING MUST BE SO ARRANGED THAT HOARDING PANELS ARE STABLE UNDER ALL CONDITIONS

TYPICAL SECTION – HOARDING WITHOUT POSTHOLES

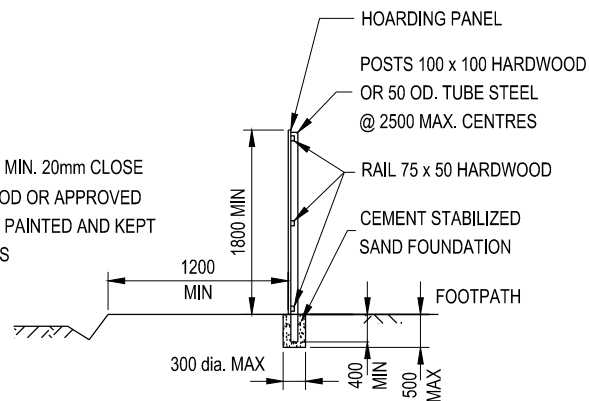

TYPICAL SECTION – HOARDING WITH POSTHOLES



**STANDARD PLAN
HOARDINGS**

CERTIFICATION

[Signature]
DEREK ROTTER - MANAGER PROJECT DELIVERY

DATE OF ISSUE: Sept 2015
SHEET NO.: 1 OF 1

MP814