

NOTES:

1. ALL WELDS TO BE 6mm FILLET UNLESS SHOWN OTHERWISE.
2. AFTER FABRICATION GRILLE AND FIXING RODS TO BE HOT DIPPED GALVANISED IN ACCORDANCE WITH AS/NZ 4680:1999
3. PROVIDE SUITABLE HOLES FOR ALL MATERIALS TO BE GALVANISED AS REQUIRED.
4. ALL END BARS TO BE 40 DIA. N.B. HEAVY WT PIPE.

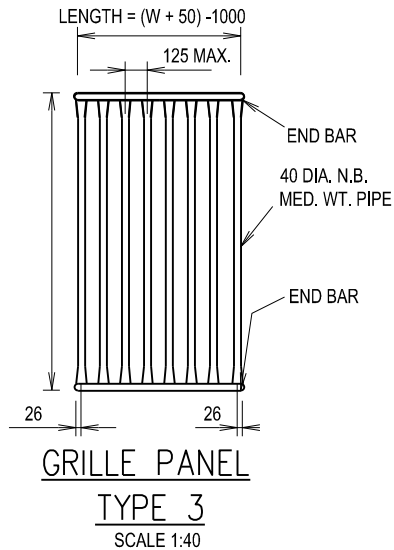
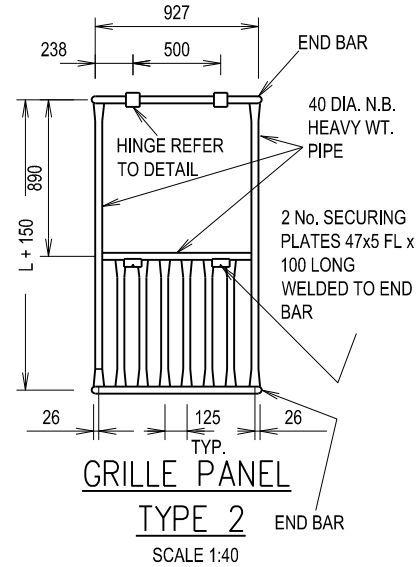
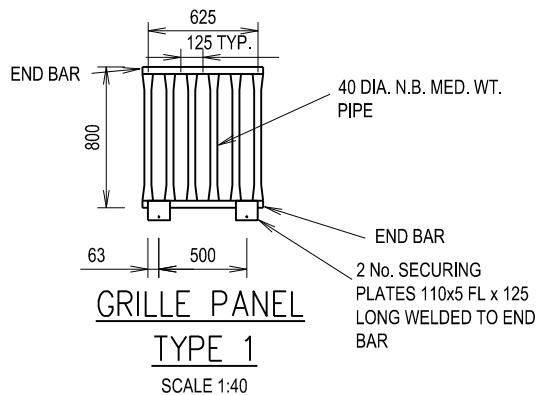
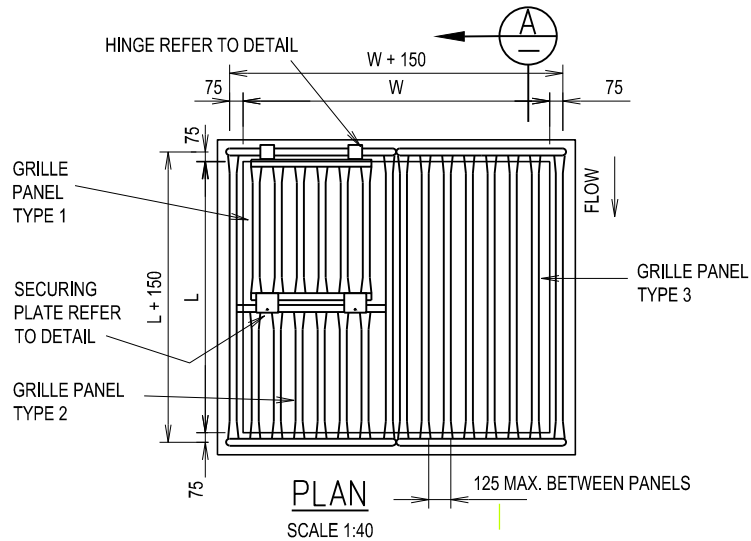

MORNINGTON PENINSULA
Shire

STANDARD PLAN

**PIPE GRILLE
FOR PIT OPENING GREATER
THAN 900 x 900**

CERTIFICATION

D. Rotter
DEREK ROTTER - MANAGER PROJECT DELIVERY

DATE OF ISSUE: Sept 2015

SHEET NO.: 1 OF 2

MP229